

Materica

TIPOLOGIE DI APERTURA

- SCORR. INTERNO MURO
- FILOMURO

TYPES OF OPENING SYSTEMS

- POCKET DOOR
- FILOMURO

La collezione Materica permette di realizzare porte nelle quali l'alluminio ospita molteplici materiali, dalla pietra alla lamina metallica fino a gres porcellanato e alla ceramica. Il risultato è un'anta che, se inserita su una parete materica, diventa parte integrante dell'architettura, una vera e propria porzione di muro che si apre sullo spazio circostante.

The Materica collection permits the creation of doors in which aluminium accommodates multiple materials, from back-painted glass to stone, metallic foil, porcelain stoneware and ceramic. The result is a door that becomes an integral part of the architecture when inserted into a material wall, becoming a part of the same that opens onto the surrounding space.

La colección Materica permite realizar puertas en las que el aluminio alberga múltiples materiales, desde la piedra y la lámina metálica, hasta el gres porcelánico y la cerámica. El resultado obtenido es una hoja que, si se introduce en una pared matérica, se convierte en parte

integrante de la arquitectura, así como en una verdadera y propia porción de pared que se abre en el espacio circunstante.

La collection Materica permet de réaliser des portes qui allient l'aluminium et différents matériaux, tels que la pierre, la lame métallique, le grès cérame et la céramique. Le résultat est une porte qui, lorsqu'elle est insérée dans un mur, devient une partie intégrante de l'architecture, une véritable portion du mur qui s'ouvre sur l'espace autour.

Die Kollektion Materica ermöglicht die Anfertigung von Türen, bei denen das Aluminium unterschiedlichste Materialien wie Stein, Metallblech, Feinsteinzeug und Keramik aufnimmt. Das Ergebnis ist ein Türflügel, der sich in eine strukturierte Wand integriert und zu einem festen Bestandteil der Architektur wird, ein regelrechter Wandabschnitt, der sich zu dem umliegenden Raum öffnet.

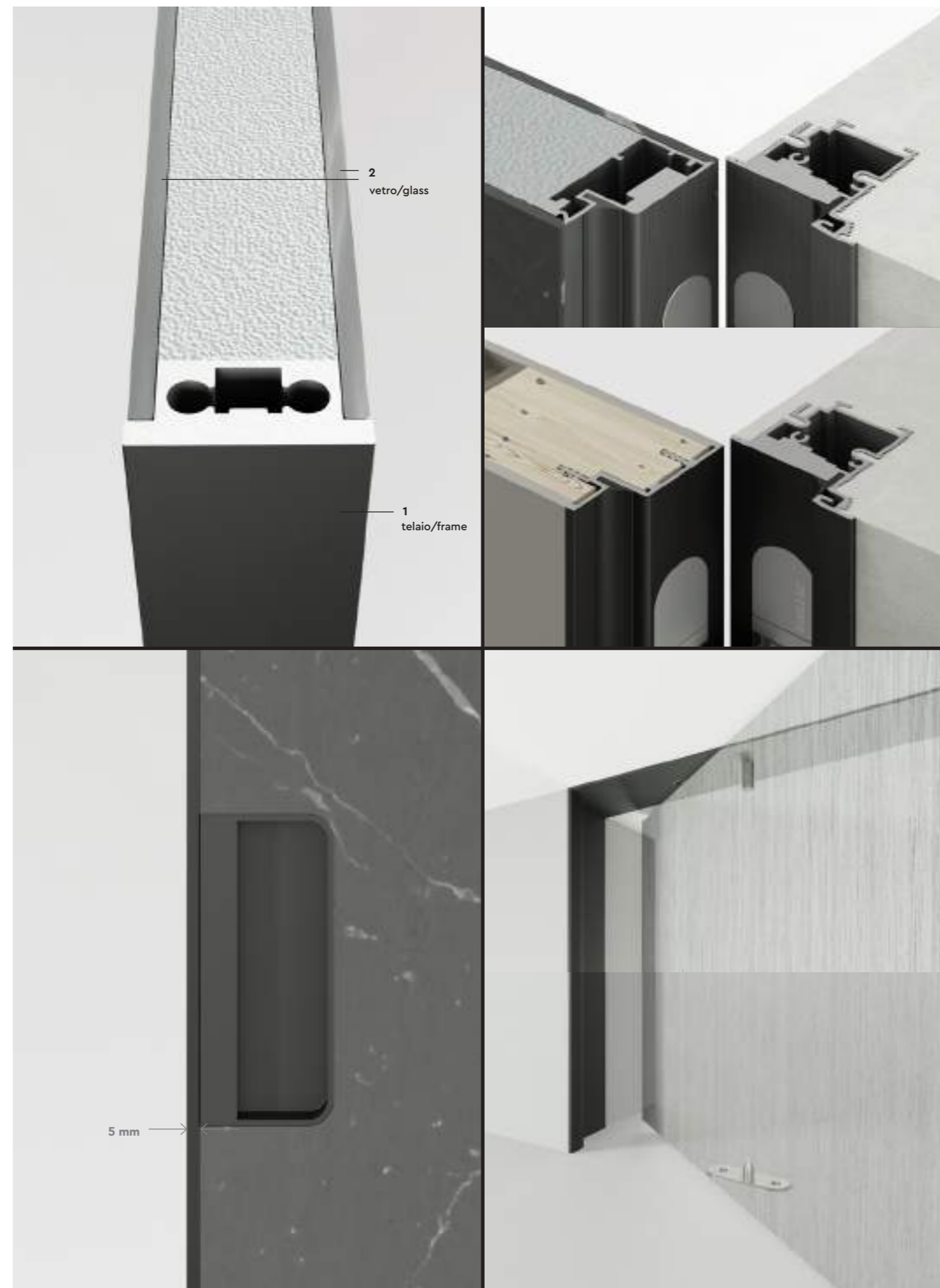



▲
controtelaio: senza stipiti
telaio anta: nero
specchiatura: MDi by Inalco
maniglia: X22
dimensioni: 800x2400 mm

counterframe: without jambs
door frame: black
door panel: MDi by Inalco
handle: X22
size: 800x2400 mm



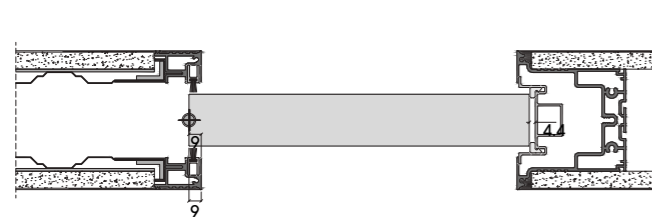
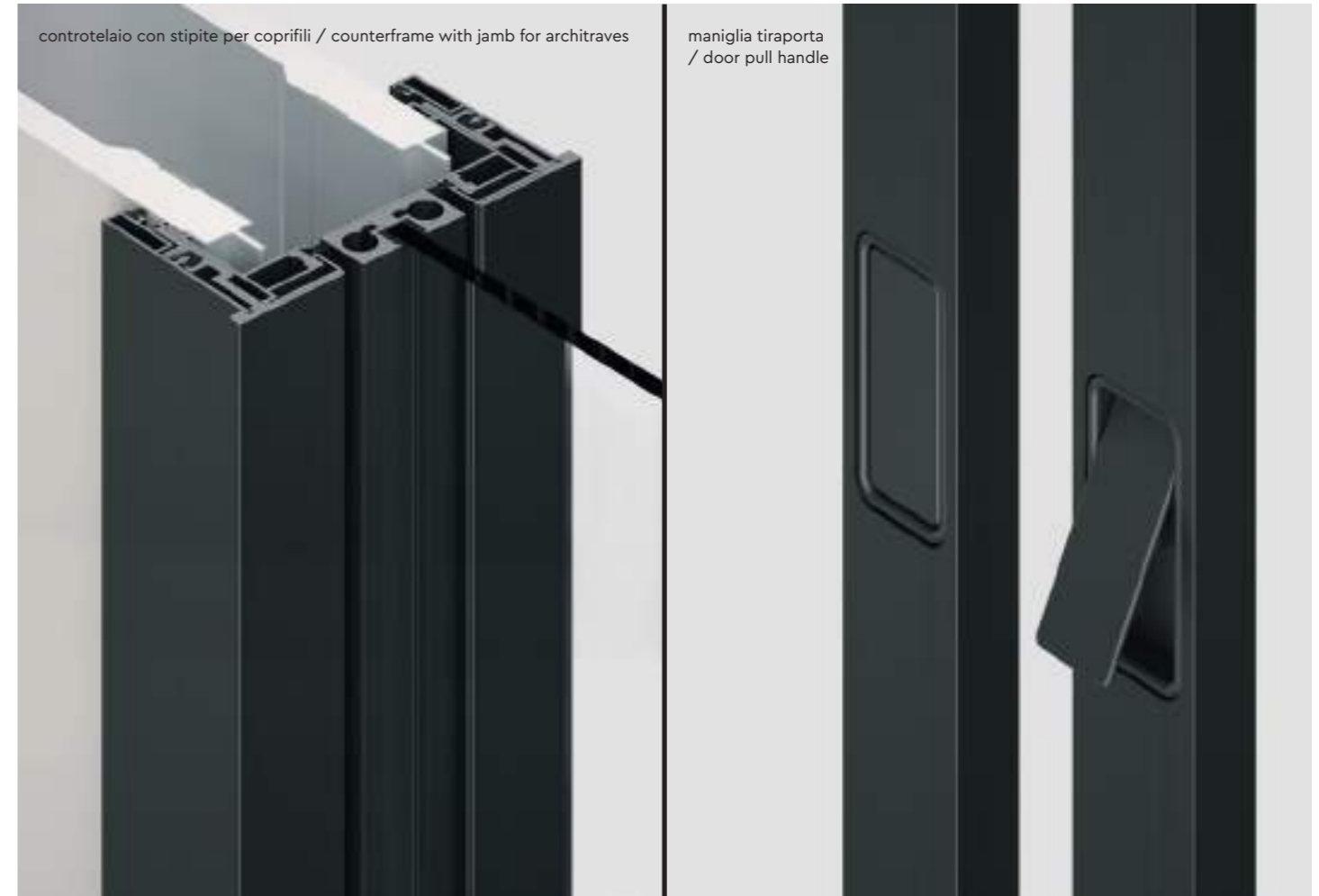

senza stipite / without jamb

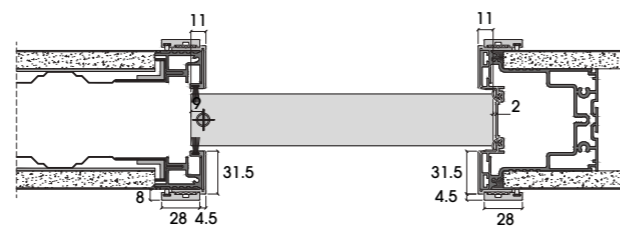

stipite minimal / minimal jamb

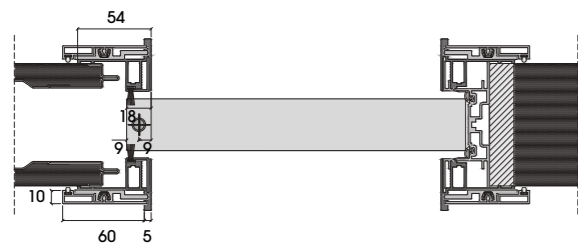

stipite con coprifilo L60 / jamb with L60 architrave

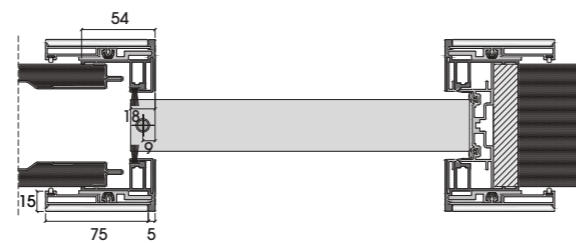

stipite con coprifilo L75 in vetro / jamb with L75 glass architrave

CARATTERISTICHE TECNICHE
TECHNICAL FEATURES

Le caratteristiche variano leggermente in funzione del controtelaio installato, che determina la scelta tra senza stipite, stipite minimal o stipite per coprifili. In tutti i casi è di serie l'apertura totale e la maniglia tiraporta.

The characteristics vary slightly, depending on the counter frame, which determines the elimination of the jamb, or the use of a minimal jamb or a cable cover jamb. In all cases, the full opening and a door handle are supplied as a standard.

Las características varían un poco dependiendo del contramarco instalado que determina la elección entre sin jamba, jamba minimalista o jamba para cubrecables. En todos los casos es de serie la apertura total y la manilla tirador.

Les caractéristiques varient légèrement en fonction du contre-cadre installé, ce qui détermine le choix entre finition sans chambranle, chambranle minimal ou chambranle pour goulottes électriques. Dans tous les cas, l'ouverture totale et la poignée pour tirer et fermer la porte sont fournies en série.

Die Eigenschaften unterscheiden sich leicht je nach installiertem Gegenrahmen, der festlegt, ob die Tür ohne Zarge, mit minimaler Zarge oder mit Zargenabdeckungen installiert wird. Serienmäßig sind immer die maximale Öffnungsweite und der Griff zum Ziehen der Tür.





▲
apertura: battente
telaio: testa di moro
specchiatura: travertino
maniglia: A50 con inserto testa di moro
dimensioni: 900x2700 mm

opening: swing
frame: testa di moro
door panel: travertino
handle: A50 with testa di moro insert
size: 900x2700 mm



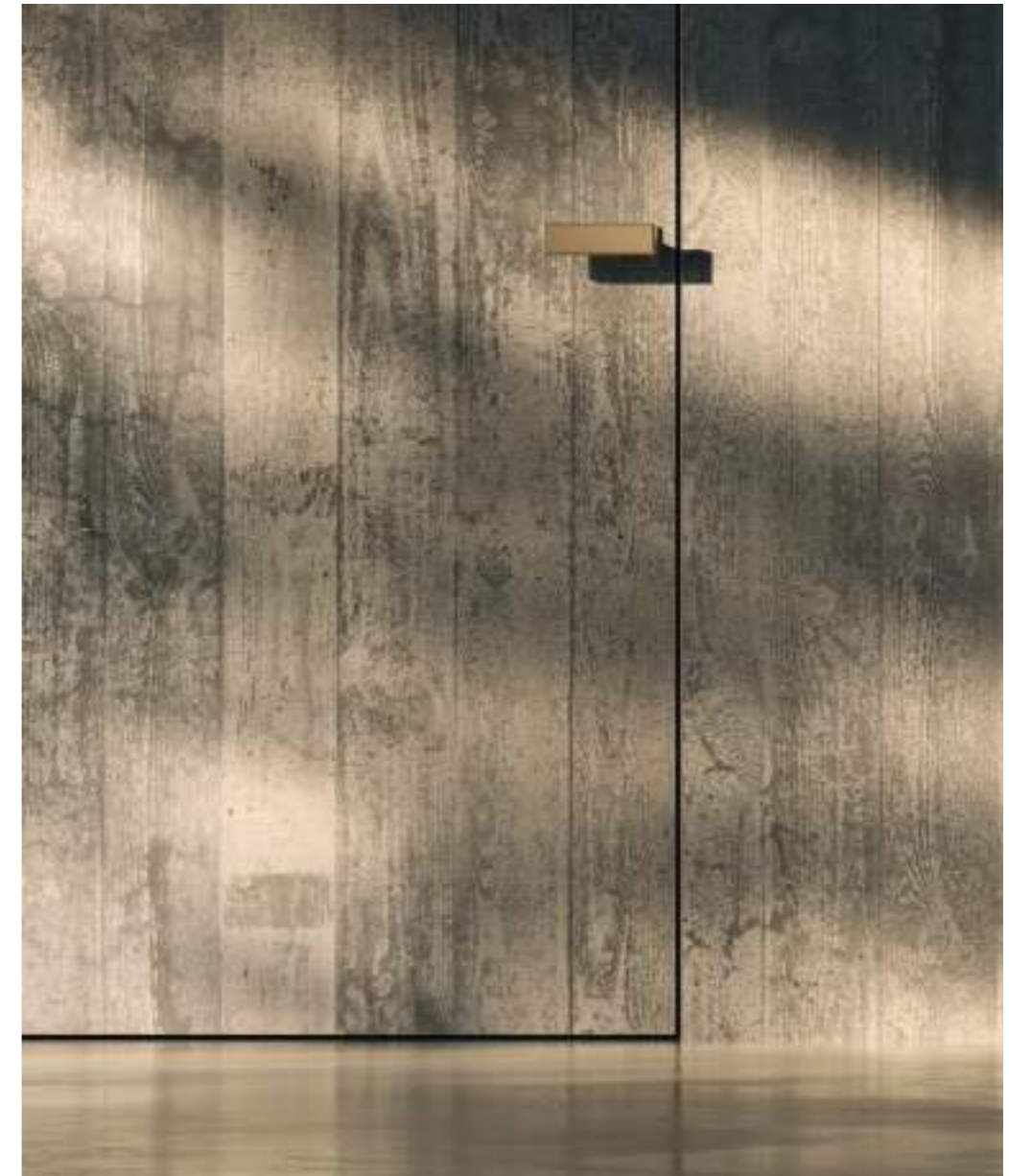

▲
apertura: bilico
telaio: laccato RAL
specchiatura: cemento
maniglia: A50 con inserto laccato RAL
dimensioni: 1600x2800 mm

opening: pivot
frame: lacquered RAL
door panel: cemento
handle: A50 with lacquered RAL insert
size: 1600x2800 mm



▲
apertura: battente
telaio: nero
specchiatura: legno
maniglia: A50 con inserto nero
dimensioni: 900x2800 mm

opening: swing
frame: black
door panel: wood
handle: A50 with black insert
size: 900x2800 mm



Materica_04

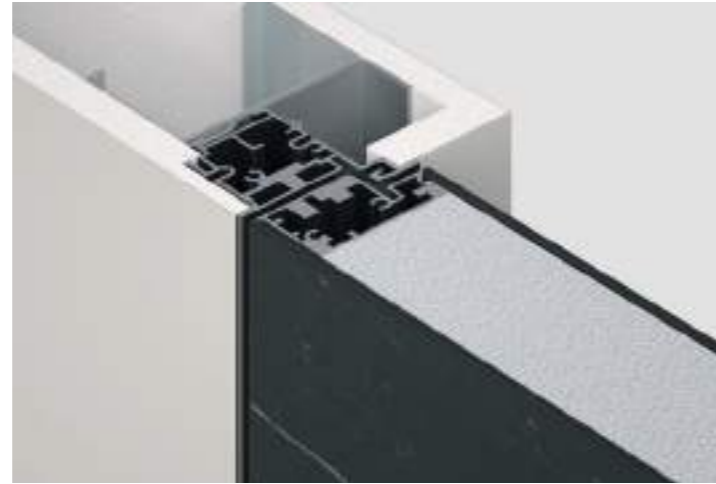

Materica_09



BATTENTE / SWING

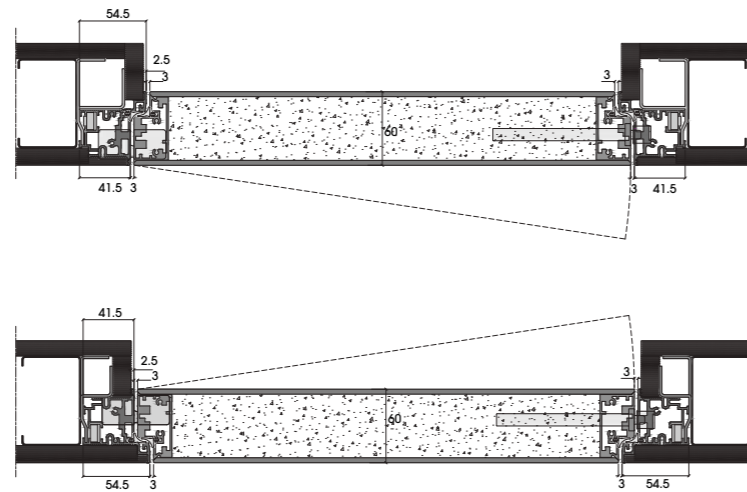
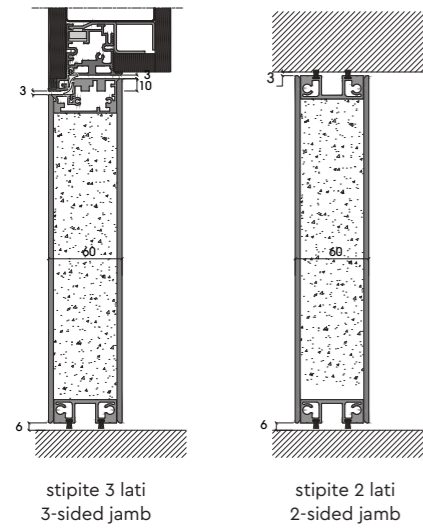

BATTENTE / SWING

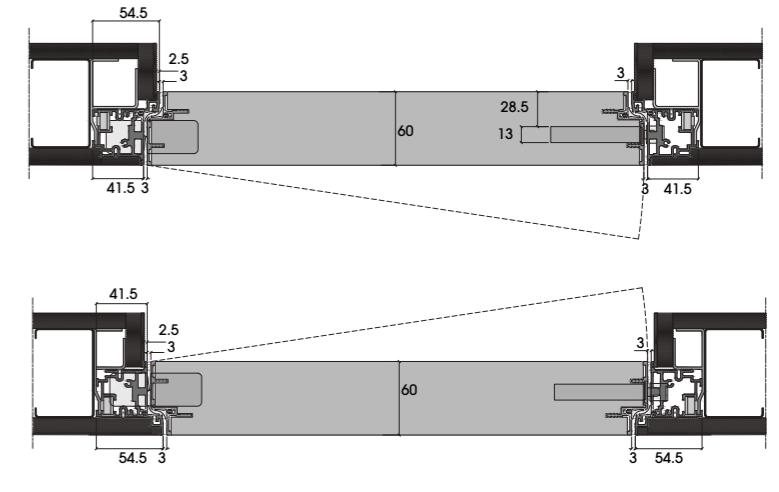
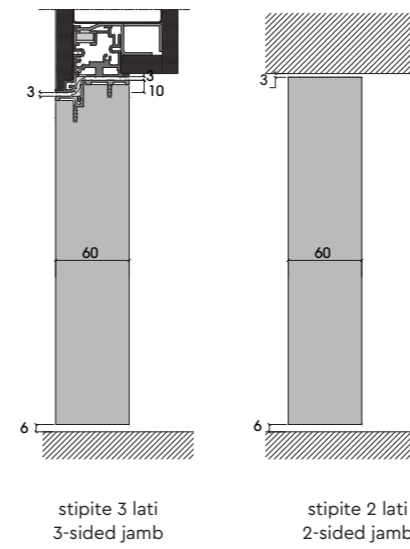

BILICO CON BATTUTA / PIVOT WITH STOP

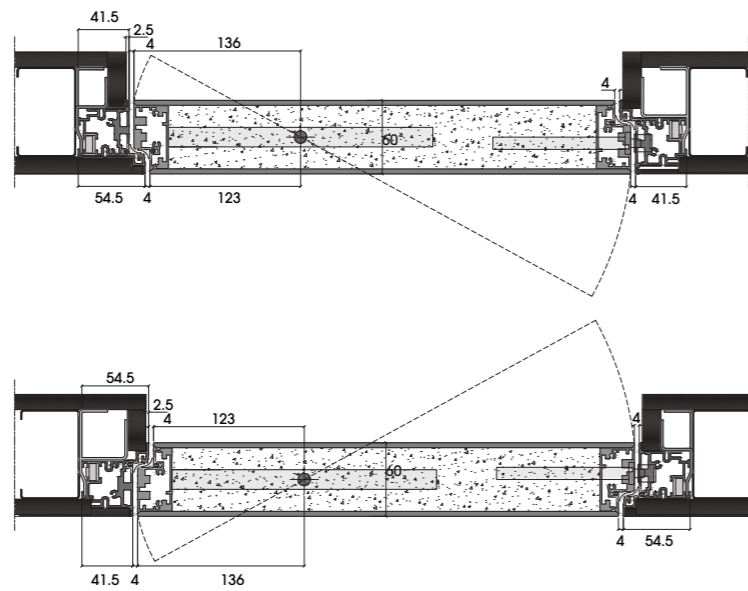
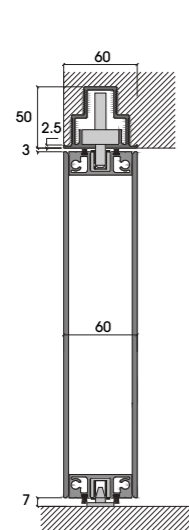

BILICO CON BATTUTA / PIVOT WITH STOP

